

APPENDIX A
 SAE FATIGUE DESIGN & EVALUATION
 T-JOINT TEST SPECIMEN GEOMETRY

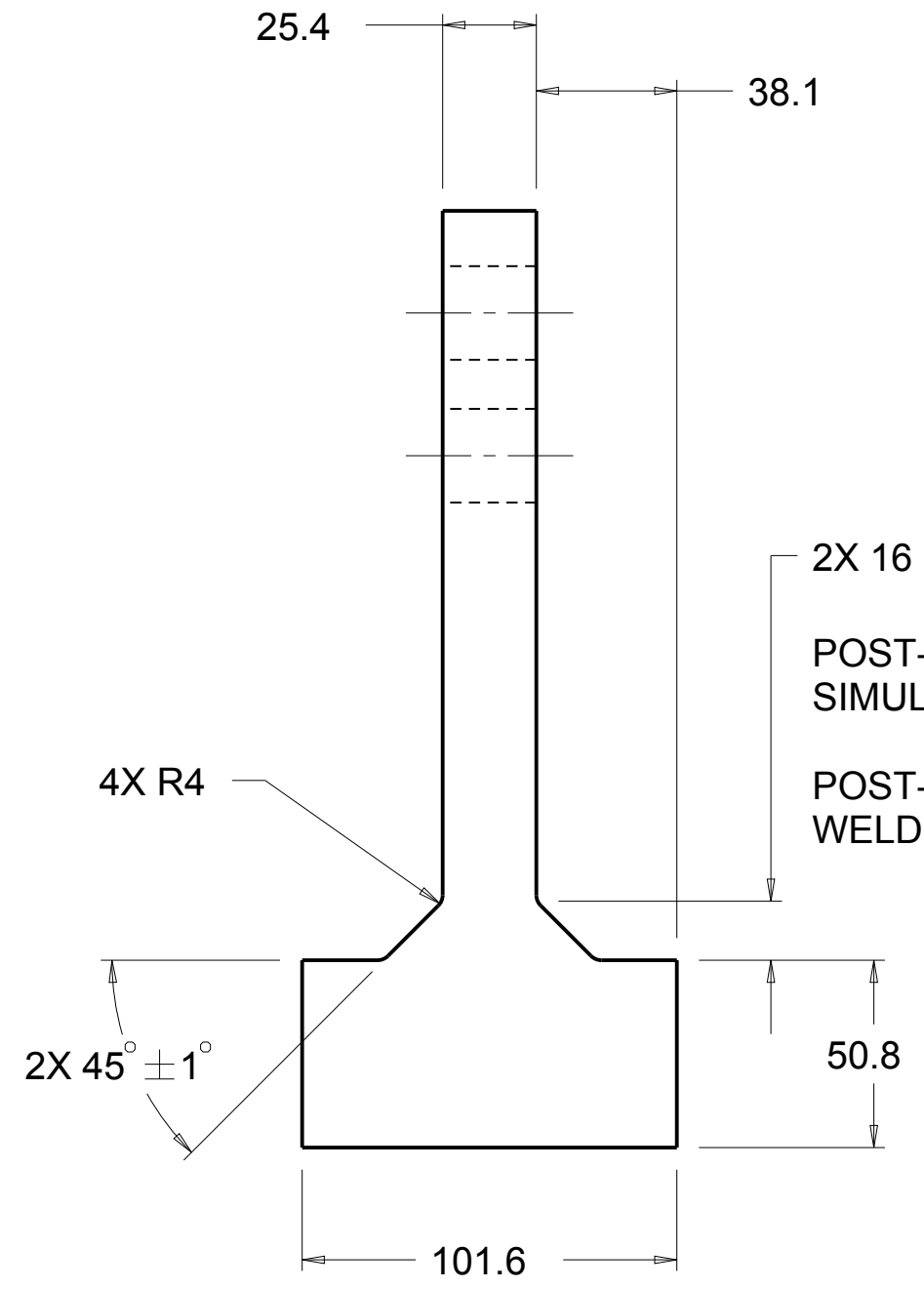

POST-TEST MACHINED SPECIMEN
 SIMULATED WELD LEG MEASUREMENT = 14.3
 POST-TEST WELDED SPECIMEN
 WELD LEG MEASUREMENT = 16.5

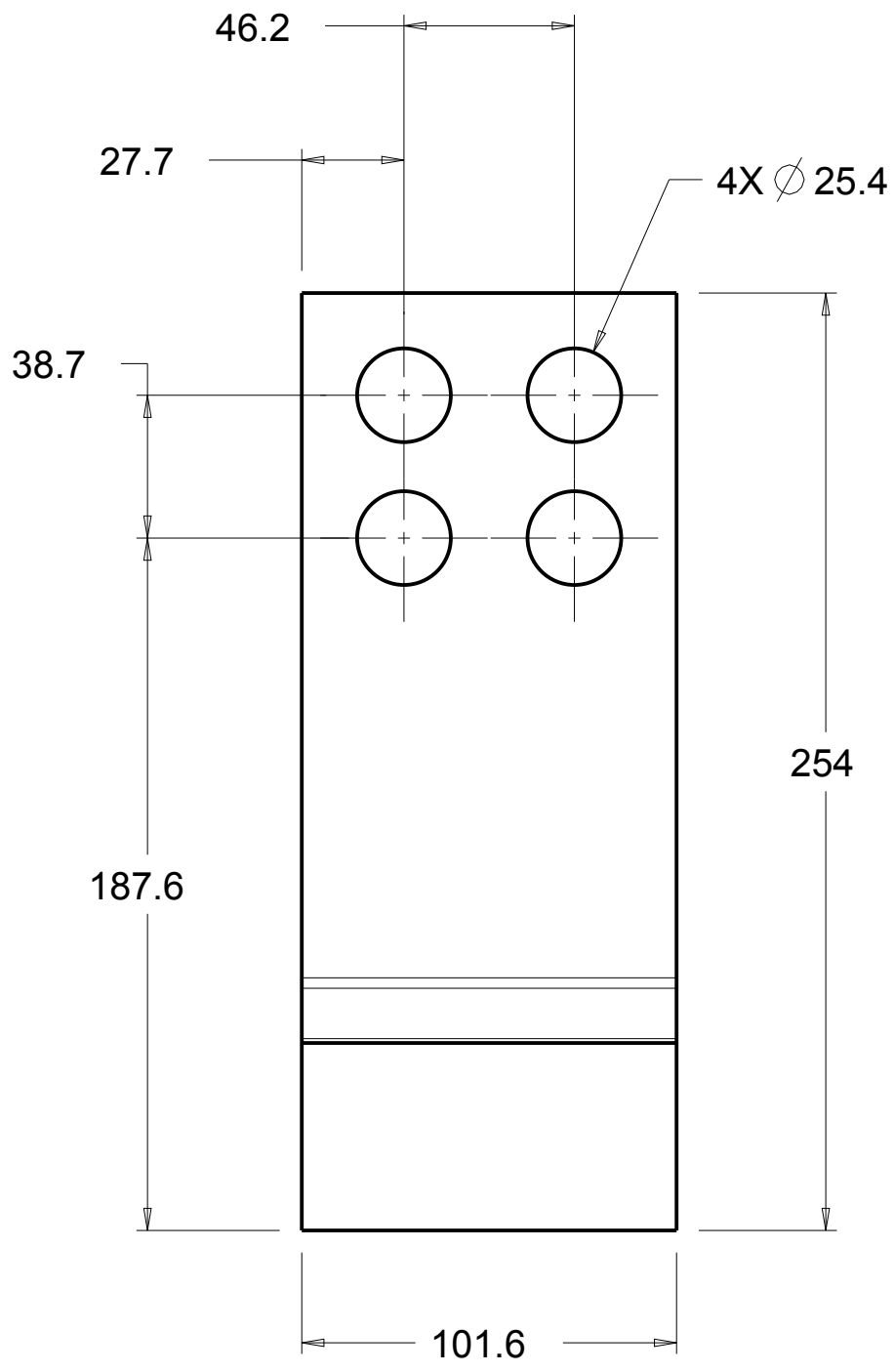
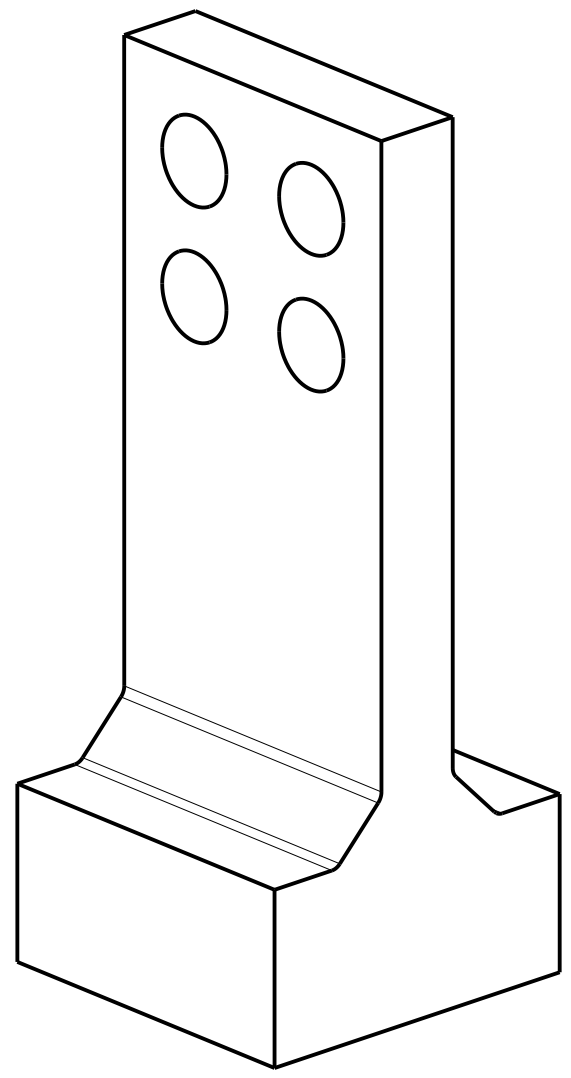

- NOTES:
 1. UNITS: MM
 2. TOLERANCE ±0.25MM UNLESS NOTED
 3. DEBURR ALL EDGES
 4. MACHINED SURFACES Ra = 1.6 MICROMETERS
 5. MATERIAL: A36 STEEL AS PROVIDED
 6. SCALE: 1:2